

Fuji

FA-20 Series Angle Grinders



- **Compact & Low Head**
- **Powerful**
- **Low Vibration**

FA-20 series angle grinders are compact and versatile 2" angle grinders and 6mm and 1/4" collet die grinders. Thanks to the powerful motor and low head design, FA-20 series are ideal for the applications with difficulty of grinding work or very limited space for grinding in die & mold workshop, foundry, rolling stock, shipyard and general metal working.



FA-20 Series Angle Grinders

FEATURES & BENEFITS

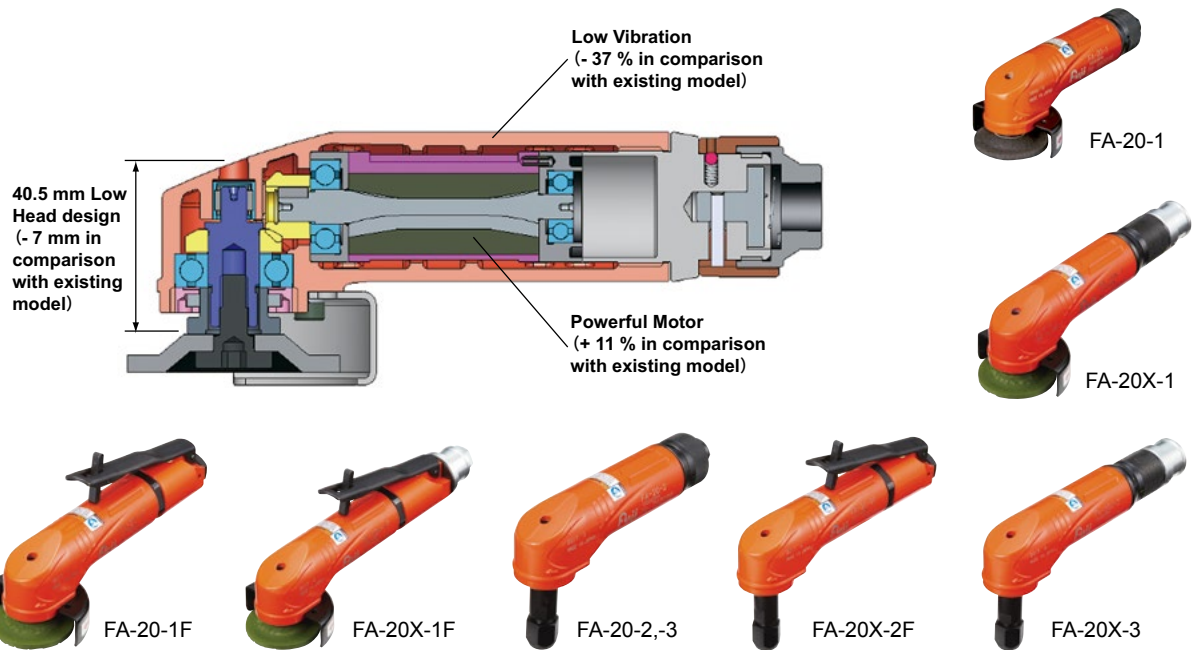

SPECIFICATIONS

Angle Grinders

Model	Part Number	Throttle Type	Max Dia.(Wheel size)		Spindle Thread	Free Speed rpm	Power		Overall Length		Weight		Max. Air consumption		Vibration m/s ²	Inlet in
			mm	in			W	hp	mm	in	kg	lb	m ³ /min	cfm		
FA-20-1	5412104835	Roll	50 x 4 x 9.53	2 x 5/32 x 3/8	1/4-28UNF(F)	15000	294	0.40	157	6.2	0.6	1.3	0.59	20.8	2.7	1/4 Rc
FA-20-1 N	5412105230	Roll	50 x 4 x 9.53	2 x 5/32 x 3/8	1/4-28UNF(F)	15000	294	0.40	157	6.2	0.6	1.3	0.59	20.8	2.7	1/4 NPT
FA-20-1F	5412104836	Lock-off Lever	50 x 4 x 9.53	2 x 5/32 x 3/8	1/4-28UNF(F)	15000	283	0.38	186	7.3	0.7	1.5	0.56	19.8	2.9	1/4 Rc
FA-20-1F N EC	5412104840	Lock-off Lever	50 x 4 x 9.53	2 x 5/32 x 3/8	1/4-28UNF(F)	15000	283	0.38	186	7.3	0.7	1.5	0.56	19.8	2.9	1/4 NPT
FA-20X-1	5412104841	Roll	50 x 4 x 9.53	2 x 5/32 x 3/8	1/4-28UNF(F)	15000	266	0.36	191	7.5	0.8	1.8	0.51	18.0	2.6	1/4 Rc
FA-20X-1F	5412104842	Lock-off Lever	50 x 4 x 9.53	2 x 5/32 x 3/8	1/4-28UNF(F)	15000	265	0.36	220	8.7	0.8	1.8	0.54	19.1	2.9	1/4 Rc
FA-20X-1F N EC	5412104845	Lock-off Lever	50 x 4 x 9.53	2 x 5/32 x 3/8	1/4-28UNF(F)	15000	265	0.36	220	8.7	0.8	1.8	0.54	19.1	2.9	1/4 NPT

Die Grinders

Model	Part Number	Throttle Type	Max Dia.(Wheel size)		Spindle Thread	Collet size mm in	Free Speed rpm	Power		Overall Length		Weight		Max. Air consumption		Vibration m/s ²	Inlet in
			mm	in				W	hp	mm	in	kg	lb	m ³ /min	cfm		
FA-20-2 1/4 N EC	5412104843	Roll	38 x 13 x-	1 1/2 x 1/2 x-	3/8-24UNF(M)	- 1/4	15000	294	0.39	157	6.2	0.6	1.3	0.59	20.8	3.2	1/4 NPT
FA-20-2 6	5412104837	Roll	38 x 13 x-	1 1/2 x 1/2 x-	3/8-24UNF(M)	6 -	15000	294	0.39	157	6.2	0.6	1.3	0.59	20.8	3.2	1/4 Rc
FA-20-2F 1/4 N EC	5412105193	Lock-off Lever	38 x 13 x-	1 1/2 x 1/2 x-	3/8-24UNF(M)	- 1/4	15000	283	0.38	186	7.3	0.7	1.5	0.56	19.8	3.1	1/4 NPT
FA-20-2F 6	5412104844	Lock-off Lever	38 x 13 x-	1 1/2 x 1/2 x-	3/8-24UNF(M)	6 -	15000	283	0.38	186	7.3	0.7	1.5	0.56	19.8	3.1	1/4 Rc
FA-20-2F 6 N EC	5412104838	Lock-off Lever	38 x 13 x-	1 1/2 x 1/2 x-	3/8-24UNF(M)	6 -	15000	283	0.38	186	7.3	0.7	1.5	0.56	19.8	3.1	1/4 NPT
FA-20-3 6	5412104839	Roll	38 x 13 x-	1 1/2 x 1/2 x-	W3/8-16(M)	6 -	15000	294	0.39	157	6.2	0.6	1.3	0.59	20.8	3.2	1/4 Rc
FA-20X-3 6	5412104846	Roll	38 x 13 x-	1 1/2 x 1/2 x-	W3/8-16(M)	6 -	15000	266	0.36	191	7.5	0.8	1.8	0.51	18.0	3.1	1/4 Rc

*FA-20- series: side exhaust

*FA-20X- series: rear exhaust

*Air hose size: 9.5mm, 3/8"

Fuji Authorized Distributor:



www.fujitools.com