

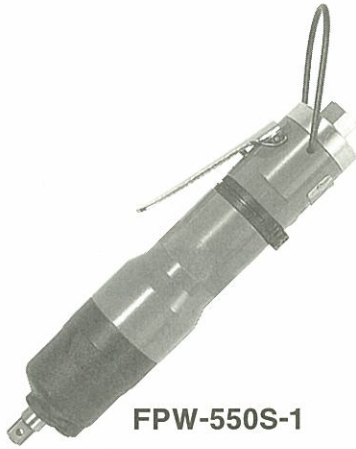

USER MANUAL

PNEUPULSE

MODELS : FPW-550S-1, -550SD-1, -10



FPW-550S-1



FPW-550SD-1, -10

(BIT SIZE)

	FPW-550SD-1	FPW-550SD-10
	A : 9.5mm	A : 13mm
	B : 12mm	B : 16mm

SPECIFICATIONS

Model	Capacity Bolt Size (Guidance)		Adjustable Torque Range (about)			Free Speed (about)	Side to Center (about)		Square Drive Size		Overall Length (without socket) (about)		Mass (without socket) (about)		Air Consumption at Max. Torque (about)		Air Inlet Thread Size
	mm	in	N·m	kgf·m	ft·lbs	rpm	mm	in	mm	in	mm	in	kg	lb	Nm ³ /min	Nft ³ /min	PT or NPT
FPW-550S-1	6~8	1/4~5/16	27~44	2.8~4.5	20~33	5,700	22.5	5/8	9.5	3/8	221	8 45/64	0.87	1.9	0.37	13.1	1/4"
FPW-550SD-1	4~6	5/32~1/4	20~34	2.0~3.5	14~25	5,700	22.5	5/8	6.35	1/4	226	8 29/32	0.88	1.9	0.37	13.1	1/4"
FPW-550SD-10	4~6	5/32~1/4	20~34	2.0~3.5	14~25	5,700	22.5	5/8	6.35	1/4	226	8 29/32	0.88	1.9	0.37	13.1	1/4"

Air Hose Size: 6.3mm (1/4")

The performance figures are at 0.63MPa (6.3bar).

⚠ Refer to "The Instructions and Warning for Safety Use" enclosed in each tool box.

FUJI AIR TOOLS CO., LTD.

2-1-14 Kamiji, Higashinariku, Osaka, 537-0003 Japan

Tel : (06) 972-2335

Fax : (06) 972-2250



PARTS LIST MODEL: FPW-550S-1, -550SD-1, -10

EXPLODED VIEW

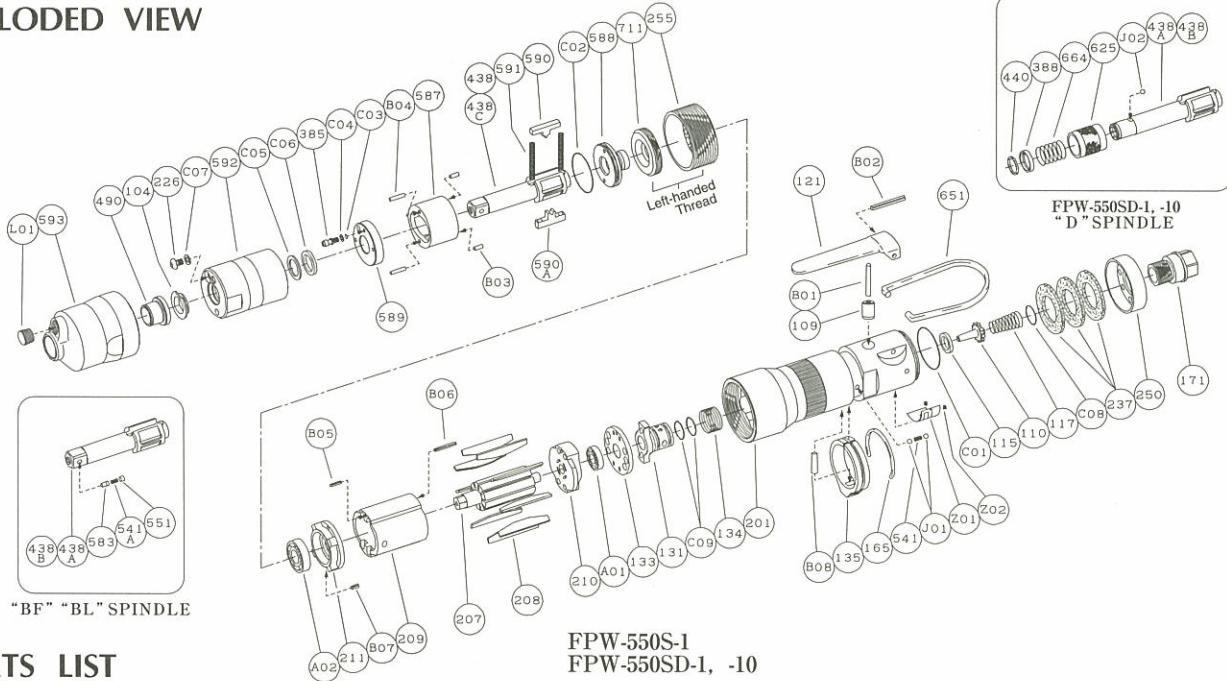

PARTS LIST

FPW-550S-1
FPW-550SD-1, -10

Index No.	Parts No.	Parts Name	Qt.
FPW-550S-1 FPW-550SD-1, -10			
CP No.	W-298006-00	Housing CP	
109	W-299109-00	Throttle Valve Bushing	1
110	W-299110-00	Throttle Valve	1
115	W-299115-00	Throttle Valve Sheet	1
117	D-001117-00	Throttle Valve Spring	1
121	M-073121-00	Throttle Valve Lever	1
171	W-299171-00	Inlet Joint (PT)	1
171	W-299171-01	Inlet Joint (NPT)	1
201	W-298201-00	Housing	1
237	W-299237-00	Muffler Pad	3
250	W-299250-00	Exhaust Cover	1
B01	NR-321FR	Needle Roller	1
B02	SP-325	Spring Pin	1
C01	O-S28F	"O" Ring	1
CP No.	W-285021-00	Oil Cylinder CP (P)	
CP No.	W-285021-01	Oil Cylinder CP (BF)	
104	W-254104-00	Bushing	1
226	W-184226-00	Oil Plug	1
385	W-254385-00	Adjusting Screw	1
438	W-285438-00	Spindle (P)	1
438A	W-285438-01	Spindle (B)	1
(541A)	W-252541-00	Button Retainer Spring (F)	1
551	W-252551-00	Plug	1
583	W-252583-00	Retainer Button (F)	1
587	W-285587-00	Oil Cylinder	1
588	W-254588-01	Oil Cylinder Upper Plate	1
589	W-254589-00	Oil Cylinder Lower Plate	1
590	W-285590-00	Spindle Blade	1
590A	W-285590-01	Spindle Blade	1
591	W-254591-00	Blade Spring	2
592	W-285592-00	Cylinder Case	1
711	W-254711-00	Cylinder Cover	1
B03	NR-2.56	Needle Roller	2
B04	NR-2.512	Needle Roller	2
C02	O-S27.5F (H)	"O" Ring	1
C03	O-S2F (H)	"O" Ring	1
C04	BR-S2.5FT2	Back Up Ring	1
C05	BR-112	Back Up Ring	1
C06	O-KX12 (H)	"X" Ring	1
C07	O-S3 (H)	"O" Ring	1
CP No.	W-285033-00	Front Case CP	
490	W-254490-00	Spindle Bushing	1
593	W-285593-00	Front Case	1
L01	PL-1/8	Plug	1
131	W-299131-00	Reverse Valve	1
133	W-299133-00	Reverse Valve Sheet	1
134	W-299134-00	Reverse Valve Spring	1
135	W-216135-00	Reverse Valve Lever	1

Index No.	Parts No.	Parts Name	Qt.
165	W-216165-00	Stop Ring	1
207	W-285207-00	Rotor	1
208	W-285208-00	Rotor Blade	9
209	W-298209-00	Cylinder	1
(B05)	SP-28	Spring Pin	1
(B06)	SP-216	Spring Pin	1
210	W-299210-00	Cylinder Upper Plate	1
211	W-299211-00	Cylinder Lower Plate	1
(B07)	SP-2.55	Spring Pin	1
255	W-299255-00	Motor Fastening Nut	1
541	W-252541-00	Button Retainer Spring (F)	1
651	W-100651-00	Hanger	1
A01	BB-EE2	Ball Bearing	1
A02	BB-EE3	Ball Bearing	1
B08	NR-413.5	Needle Roller	1
C08	O-S12.5	"O" Ring	1
C09	O-S12.5	"O" Ring	2
J01	B-3	Ball	2
Z01	NP-1076	Name Plate	1
Z02	NPN-0X3.2	Screw Rivet	2
"PL" SPINDLE			
CP No.	W-285021-08	Oil Cylinder CP (PL)	
438C	W-285438-07	Spindle (P)	1
"BL" SPINDLE			
CP No.	W-285021-09	Oil Cylinder CP (BL)	
438B	W-285438-08	Spindle (B)	1
(541A)	W-252541-00	Button Retainer Spring (F)	1
551	W-252551-00	Plug	1
583	W-252583-00	Retainer Button (F)	1
FPW-550SD-1			
CP No.	W-298006-01	Housing CP	
201	W-298201-01	Housing	1
CP No.	W-285021-06	Oil Cylinder CP (D)	
438A	W-285438-05	Spindle (D)	1
388	W-305388-00	Spring Holder	1
440	W-305440-00	Ring	1
625	W-305625-00	Bit Cover	1
664	W-305664-00	Finder Spring	1
J02	B-3	Ball	1
FPW-550SD-10			
CP No.	W-298006-01	Housing CP	
201	W-298201-01	Housing	1
CP No.	W-285021-07	Oil Cylinder CP (D)	
438B	W-285438-06	Spindle (D)	1
388	W-305388-00	Spring Holder	1
440	W-305440-00	Ring	1
625	W-305625-00	Bit Cover	1
664	W-305664-00	Finder Spring	1
J02	B-3	Ball	1

*The length of BL, PL spindle are 5mm longer than BF, P spindle.

- CP No. denotes the assembled parts comprising of more than 1 pc. of parts. The related parts are shown in the thick frame.
- #209, 211, 438A and 438B are supplied together with parts shown in ().
- Specify parts number and quantity in ordering.

- Standard Accessories : F-701-1.....15mm Hex. Pin Wrench 1.
- F-705.....5mm Hex. Pin Wrench 1.